

MFX_4 CONTROLLER NO EX V4

The powerful MFX_4 measurement data acquisition system meets the highest standards for flexible and reliable calibration-compliant measurement, mixing and control of processes in the handling of liquids, especially mineral oils. With more than 30 years of operating experience and over 18,000 installations, the fourth generation combines many years of industry experience with state-of-the-art technologies and communication standards.

MFX_4 CONTROLLER NO EX

The MFX_4 Controller is the flow computer for custody transfer applications.

The MFX_4 Controller is also available with an approved explosion-proof housing.

All MFX_4 systems are easy to integrate, quick to configure and can be remotely maintained during operation thanks to their support for a wide range of protocols and communication standards. To significantly expand the range of possible applications, the MFX_4 measurement data acquisition system features a distributed architecture of central computing and decentralised operating units.

The MFX_4 Controller has a two-line display that remains operational in the event of a power failure [OIML requirement].

The first line always shows the measured quantity; the second line can display various configurable values such as density, temperature, net volume, etc.



MFX_4 Controller No Ex V4



MFX_4 CONTROLLER NO EX V4

TECHNICAL DATA / FEATURES

Approvals

- PTB Type-Approval Certificate [W&M approved]
- OIML R117-1 2007
- MID Type-Examination Certificate
- several more national approvals

Weight

- 1.100 g

Operating temperature

- -20 °C ... +40 °C (see installation instructions)

Supply voltage

- 24 VDC $\pm 10\%$
P_{typ} = 8 W P_{max} = 15 W
(without using the analogue output)
P_{max} = 40 W
(with using the analogue output) 0...400 mA)

Interfaces

- CAN-Bus (with electrical isolation)
- RS232 or RS485 (with electrical isolation)

RS485 Termination

- Can be disabled via DIP switch

Housing

- Aluminium / ABS, black, IP 20
DIN rail module: W 93 mm x H 128 mm x D 158 mm
Minimum clearance: left/right 10 mm
top/bottom 50 mm

Storage temperature

- -25 °C...+75 °C

Display

- Alphanumeric display; 2x16 characters
LED backlighting
5 minutes display buffering in case of power failure
[OIML requirement]

Protocols

- CANopen
- MODBUS RTU
- TCP/IP via MFX_4 EDI or MFX_4 Terminal
- MODBUS TCP via MFX_4 EDI

LED

- | | | | |
|-----------|----------|-----------|----------|
| • Power | (green) | • Pulse | (yellow) |
| • Connect | (green) | • Loading | (yellow) |
| • CAN_T | (yellow) | • Error | (red) |
| • CAN_R | (yellow) | | |

MFX_4 CONTROLLER NO EX V4

SINGLE METER VERSION

Pulse input

- 1x pulse input (double pulse) (2 KHz)
- 1x pulse input (single pulse) (2 KHz)
- 4x pulse input (single pulse) (200Hz) when using the digital inputs 1-4

Temperature measurement

- 1x resistance thermometer PT100 4 wires

Density measurement

- 1x direct density input [frequency]
- 1x resistance thermometer PT100 4 wires or via 20 mA input (not calibratable)

Analogue inputs

- 2x (4x*) analogue inputs 0/4 ...20 mA
e.g.: Pressure, density measurement etc.

Analogue outputs

- 2x analogue outputs 0/4 ...20 mA
e.g.: Flow control, blending

Load outputs

- 7x AC switching outputs (230 V)
- 8x DC switching outputs (24 V)
If required: relay output, solid state, optocoupler

Digital inputs

- 12x digital inputs
The digital inputs 1 to 4 can also be used as pulse inputs (max. 200 Hz).

Pulse output

- 1x pulse output evaluated (optocoupler)
Configurable: Net volume, gross volume, mass
- 1x pulse output unweighted (optocoupler) (A/B pulse)
Copy from pulse input

* UPON REQUEST

DUAL METER VERSION

Pulse input

- 1x pulse input (A/B) double pulse) (2 KHz) (Meter 1)
- 1x pulse input (C/D) double pulse) (2 KHz) (Meter 2)
- 4x pulse input (single pulse) (200Hz) when using the digital inputs 1-4

Temperature measurement

- 1x resistance thermometer PT100 4 wire (Meter 1)
- 1x resistance thermometer PT100 4 wire (Meter 2)

Density measurement

- yes, via 20 mA input (not calibratable)

Analogue inputs

- 2x (4x*) analogue inputs 0/4 ...20 mA
e.g.: Pressure, density measurement etc.

Analogue outputs

- 2x analogue outputs 0/4 ...20 mA
e.g.: Flow control, blending

Load outputs

- 7x AC switching outputs (230 V)
- 8x DC switching outputs (24 V)
If required: relay output, solid state, optocoupler

Digital inputs

- 12x digital inputs
The digital inputs 1 to 4 can also be used as pulse inputs (max. 200 Hz).
(The inputs/outputs can be divided between the two meters as desired).

Pulse output

- 1x pulse output evaluated (optocoupler)
Configurable: Net volume, gross volume, mass
- 1x pulse output unweighted (optocoupler) (A/B pulse)
Copy from pulse input

MFX_4 CONTROLLER NO EX V4

STANDARD FUNCTIONS

- Single or multi-product operation
- Additive blending including flushing function
- Flow rate control for digital and analogue valves
- Double pulse input in accordance with ISO 6551 Level A
- Configurable inputs and outputs
- Selective chamber preselection
- K-factor setting
- Meter error curve linearisation (4 curves with up to 10 data points)
- Up to 10 products configurable
- Volume conversion according to ASTM Table 54A, B, D, X
- Volume conversion KOE calculation of up to 5 data points
- Volume conversion KOE calculation via polynomial (method 3) (biofuel-mineral fuel/heating oil mixtures)
- Temperature-quantity conversion according to DIN EN 15940 for paraffinic diesel fuels (method 2)
- Pressure compensation of the volume
- Evaluated pulse output
- Display with multilingual capability
- Automatic error handling and error reporting
- Integrated logbook for selected processes
- Manual or automatic operation
- Configurable I/O process control
- 5 levels of access authorisation
- Document memory for up to 200 processes per meter
- Configurable control functions (PLC)
- Remote maintenance via diagnostic interface

Interfaces

- CANopen communication with the MFX family
- LAN communication Ethernet TCP/IP via MFX_4 EDI
- Serial interfaces RS232/RS485
- OPC server, Modbus RTU, Modbus TCP via MFX_4 EDI

OPTIONAL FUNCTIONS

- Density measurement via frequency from density sensor
- Density measurement via 0/4 ... 20mA from density sensor
- Inline blending -> ratio or side
- Multi-product blending [max. 4 products]
- Additive dosing via integrated controller (analogue and digital) for max. 10 additives
- Pipeline applications
- Volume comparison for leak detection
- Master meter function
- PC-based functions:
 - MPC pipeline measuring systems and prover systems
 - Master meter function
 - UPC 2000 (calibratable data storage)
- PC-based service functions:
 - MFX_4 Explorer for device configuration
 - Remote maintenance and diagnostic tool



MFX_4 CONTROLLER NO EX V4

PRODUCT KEY / OPTIONS

	4000677 + [Basic device] + [Software] + [I/O] + [Interfaces] + [Approvals]	
Basic device	CH1 CH2	Single 24 VDC Dual 24 VDC
Software	SW00 SW01 SW02 SW03 SW04 SW05 SW06	Meter Controller + Additive Blending Controller Density Pipeline Pipeline leakage detection Master meter Master meter (duty meter)
I/O	ADR R13 4A9 4D9	7 AC Solid state relays + 8 DC Solid state relays 13 mechanical relays 4 Solid state (AC) + 9 mechanical relays 4 Solid state (DC) + 9 mechanical relays
Analogue inputs	A2NX A4NX A6NX	Standard (2 Input) 2 additional inputs (by arrangement, only 1xPT100 possible) 4 additional inputs (only with external hardware)
Interfaces	RS232 RS485	RS232 RS485
Approvals	C0 C1 C2 C3 BEV	without extended factory pre-test OIML, MID/ OIML, MID National, under German law Preliminary test certificate Part Certificate (BEV)

MFX_4 CONTROLLER NO EX V4

DIMENSIONS

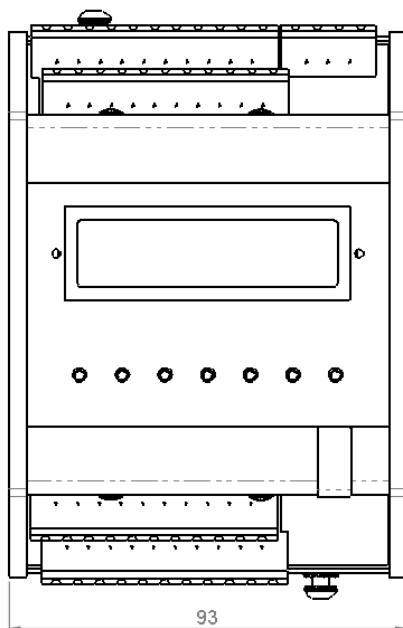
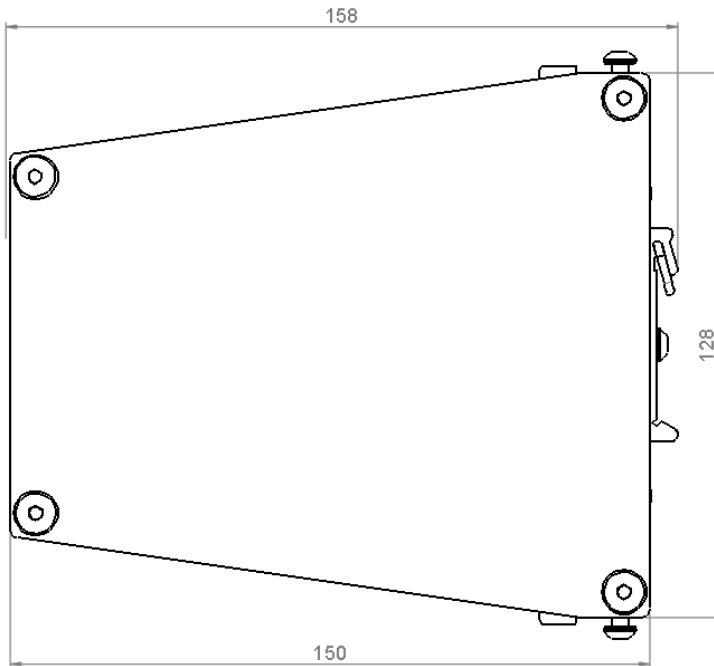

Dimensions: Dimensions in millimetres

MFX_4 CONTROLLER NO EX V4

PIN ASSIGNMENT

Top of housing

Bottom of housing

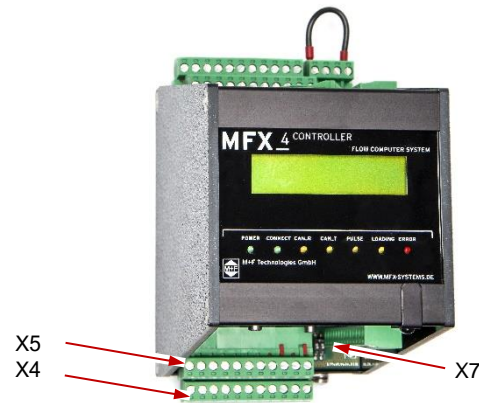

PIN	X1	X2	X3	X4	X5	X6	X7	X8
1	0V	Ain6+	Din+	IMPA+	Rx-			T2D+
2	CANL	Ain6-	Din1-	IMPA-	GNDS			T2S+
3	Shield	Ain7+	Din2-	IMPB+	Tx+			T2S-
4	CANH	Ain7-	Din3-	IMPB-	copyB-			T2D-
5	24V	T1D+	Din4-	IMPC+	copyB+			
6		T1S+	Din5-	IMPC-	copyA-			
7		T1S-	Din6-	IMPD+	copyA+			
8		T1D-	Din7-	IMPD-	DO1+			
9		AO+	GND12	GND12	DO1- / DI8			
10		AO1-	DO3+ / Din11	P+	DO2+ / Din9			
11		AO2-	DO3- / Din12	P-	DO2- / Din10			

PIN	X6			
	ADR	R13	4A9	4D9
1	GNDR	K7_1	K7_1	K7_1
2	GNDR	K7_2	K7_2	K7_2
3	K8-	K6_1	K6_1	K6_1
4	K7-	K6_2	K6_2	K6_2
5	KD+	K5_1	K5_1	K5_1
6	K6-	K5_2	K5_2	K5_2
7	K5-	K4_1	K4_AC	K4-
8	KC+	K4_2	K4_AC	K4+
9	K4-	K3_1	K3_AC	K3-
10	K3-	K3_2	K3_AC	K3+
11	KB+	K2_1	K2_AC	K2-
12	K2-	K2_2	K2_AC	K2+
13	K1-	K1_1	K1_AC	K1-
14	KA+	K1_2	K1_AC	K1+

PIN	X7			
	ADR	R13	4A9	4D9
K9_AC	GNDR2	GNDR2	GNDR2	GNDR2
K9_AC	K13_1	K13_1	K13_1	K13_1
K10_AC	K13_2	K13_2	K13_2	K13_2
K10_AC	K12_1	K12_1	K12_1	K12_1
K11_AC	K12_2	K12_2	K12_2	K12_2
K11_AC	K11_1	K11_1	K11_1	K11_1
K12_AC	K11_2	K11_2	K11_2	K11_2
K12_AC	K10_1	K10_1	K10_1	K10_1
K13_AC	K10_2	K10_2	K10_2	K10_2
K13_AC	K9_1	K9_1	K9_1	K9_1
K14_AC	K9_2	K9_2	K9_2	K9_2
K14_AC	K8_1	K8_1	K8_1	K8_1
K15_AC	K8_2	K8_2	K8_2	K8_2
K15_AC	GNDR1	GNDR1	GNDR1	GNDR1

Options for relay board: ADR - 7 AC relays + 8 DC relays R13 - Relay card with 13 relays
 4A9 - 4 AC solid state relays + 9 relays 4D9 - 4 DC solid state relays + 9 relays